

Structural Stud

C-shaped framing member

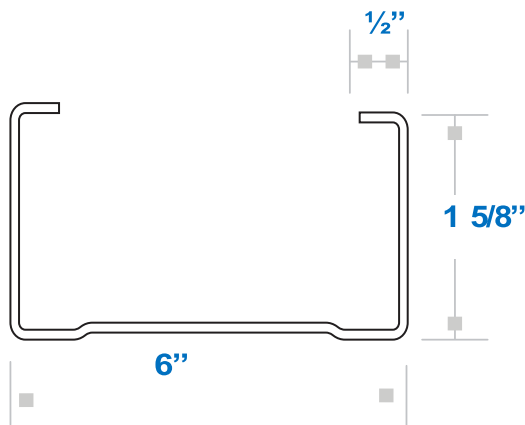

*Picture is reference only; it may differ from the actual product

This structural framing member is designed to support the weight of the gypsum board. It is also the one that receives the structural loads of a construction.

Geometric properties

Panel Rey's Structural Stud is produced with the highest quality steel, it is galvanized by the hot-dip process and has a standard G60 galvanized coating. It is manufactured with a width of 6" and has a standard height of 1 5/8".

Punchout

style	spacing	
	From End	O.C.
East	12"	24"
West	24"	24"

*Punchout dimensions as reference

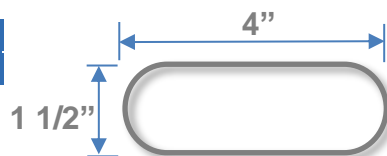

* Maximum pieces per pallet, amount could change per request.

*Consult your sales agent for special length

*Data in (), for 600S162S-54 & 68

Product Data	
Length*:	10'
Pieces per bundle:	4 (1)
Pieces per pallet*	144
Total linear feet:	1,440

Steel Thickness

member	Reference Gauge USA	Design thickness (in)	Thickness (Mils)	Minimum thickness (in)
600S162S-33	20	0.0346	33	0.0329
600S162S-43	18	0.0451	43	0.0428
600S162S-54	16	0.0566	54	0.0538
600S162S-68	14	0.0713	68	0.0677

ASTM Standards and Compliance Codes

All Panel Rey® Structural Studs meet or exceed the following ASTM standards:

- ASTM A653 *Standard Specification for Steel Sheet, Zinc-Coated (Galvanized) or Zinc-Iron Alloy-Coated (Galvannealed) by the Hot-Dip Process*
- ASTM A924/A924M *Standard Specification for General Requirements for Steel Sheet, Metallic-Coated by the Hot-Dip Process.*
- ASTM A1003 *Standard Specification for Steel Sheet, Carbon, Metallic- and Nonmetallic-Coated for Cold-Formed Framing Members*
- ASTM C 955 *Standard Specification for Cold Formed Steel Structural Framing Members*
- ASTM C754 *Standard Specification for Installation of Steel Framing Members to Receive Screw-Attached Gypsum Panel Products*
- AISI S100 & AISI S240
- 2018 IBC

LEED Credits

- **Leed v4 MR.** Raw Material Supply
- **Leed v4 MR.** Construction and Demolition Waste Management.
- **Leed v3 MR2.** Construction Waste Management. The steel used is 100% recyclable.
- **Leed v3 MR4.** Recycled Content. The steel used in the profiles has a minimum of:
 - Total recycled content: **49%**
 - Post-consumer recycled content: **37%**
 - Pre-Consumer recycled content: **12%**

Physical and Structural Properties

Product	FY (ksi)	Design Thickness (in)	Sectional properties									Effective properties 33 KSI		
			Area (in ²)	Weight (lb/ft)	Ix (in ⁴)	Sx (in ³)	Rx (in)	Iy (in ⁴)	Ry (in)	Ix (in ⁴)	Sx (in ³)	Ma (in.k)	Mad (in.k)	VaG/Vanet (lb)
600S162S-33	33	0.0346	0.344	1.17	1.793	0.598	2.282	0.116	0.581	1.793	0.577	11.41	9.11	638/638
600S162S-43	33	0.0451	0.447	1.52	2.316	0.772	2.277	0.148	0.576	2.316	0.767	16.68	12.99	1416/1240
600S162S-54	33	0.0566	0.556	1.89	2.861	0.954	2.268	0.180	0.570	2.860	0.953	21.17	17.41	2739/1890
600S162S-54	50	0.0566	0.556	1.89	2.261	0.954	2.268	0.180	0.570	2.860	0.916	30.33	23.02	2823/1947
600S162S-68*	50	0.692	0.692	2.36	3.526	1.175	2.256	0.218	0.561	3.525	1.164	39.47	31.05	5350/2879

*68 mils available in 33 KSI

Sectional Properties

Ix: Moment of inertia of gross section about the X-X axis (strong axis).

Sx: Section modulus about the X-X axis (strong axis).

Rx: Radius of gyration of the gross section about the X-X axis.

Iy: Moment of inertia of gross section about the Y-Y axis (weak axis).

Ry: Radius of gyration of the gross section about the Y-Y axis.

Effective Properties

Ixe: Effective moment of inertia about the X-axis.

Sxe: Effective section modulus about the X-X axis (strong axis) stress = Fy.

Ma: Allowable Bending Moment - Based on the effective section modulus and the allowable stress including the strength increase from the cold-work of forming (Section A3.3.2) where applicable.

Mad: Allowable Bending Moment - Based on Distortional Bucking Strength calculated per Sections F4, F4.1 of AISI S100-16.

Vag: Allowable strong axis shear away from punchout, calculated in accordance with Section G2 of AISI S100-16.

Vanet: Allowable strong axis shear at punchout, calculated in accordance with Section G3 of AISI S100-16.

Notes:

1. Calculated properties are based on AISI S100-126 "North American Specification for the Design of Cold-Formed Steel Structural Members."
2. The centerline bend radius is based upon inside corner radii shown in Table as shown in the Thickness Table (page 3).
3. Effective properties incorporate the strength increase from the cold work of forming as applicable per AISI A3.3.2.
4. Tabulated gross properties, including torsional properties, are based upon full-unreduced cross section of the studs, away from punchouts.
5. For deflection calculations, use the effective moment of inertia.
6. Allowable moment includes cold-work of forming.
7. For the steels that have both 33 and 50 ksi listing, if the design is based upon 50 ksi, the 50 ksi steel needs to be specified. (Example: 3625 S137 16-50 (50 ksi)).
8. Web depth for track sections is equal to the nominal stud width plus 2 times the design thickness plus the bend radius. Hems on nonstructural track sections are ignored.

Compound and non-compound Limited Heights Tables

For more information and tables, please refer to the SFIA "Technical Guide for Cold-Formed Steel Framing Products."

Storage

Store in a dry place to protect from moisture.

Panel Rey México, S. A. has the authority to make changes to the information in this document without prior notice. It is not possible to keep all the regulations related to the system up to date, therefore, the user must know these rules.

All claims must be in writing and supported by evidence; They must be sent within a period not exceeding 30 calendar days from the date the defect was discovered or should have been discovered and must be within the product warranty period.

The client should not alter or repair the affected area until Panel Rey has reviewed the problem and determines the possible cause. The responsibility of Panel Rey México S. A. is limited only to the replacement of the defective material and is not responsible for incidental and unforeseen damages, direct or indirect, or any loss caused by the application of these products that does not conform to the instructions or the intended use, as well as the application of the product after the expiration date.